



ULTRALITE® MULTI UV TECHNICAL GUIDE



Sawaswati Plastotech
India Pvt. Ltd

Manufacturing Unit:

Saraswati Plastotech India
Pvt Ltd
Lane 4, Phase 1, Sidco
Industrial Complex, Bari
Brahmana, Jammu 181133

Email: plasto.saraswati@gmail.com
www.saraswati-group.com

■ THE POLYCARBONATE MULTI WALL SHEET	2
At a glance technical specification	2
■ Warranty	3
■ MATERIAL PROPERTIES	6
■ CHARACTERISTICS	8
Impact strength	8
Light weight	10
Weathering resistance	11
Thermal insulation	12
Light transmission	13
Solar transmission	14
Fire behavior	16

Smoke behavior	17
Temperature resistance	18
Noise insulation	29
Chemical resistance	20
■ TRANSPORT AND STORAGE	22
Transport and handling	22
Storage	23
■ INSTALLATION	24
Installation considerations	24
Construction details	30
Preparations for installation	35
Important remarks	40
■ STATICS	45
Flat applications	47

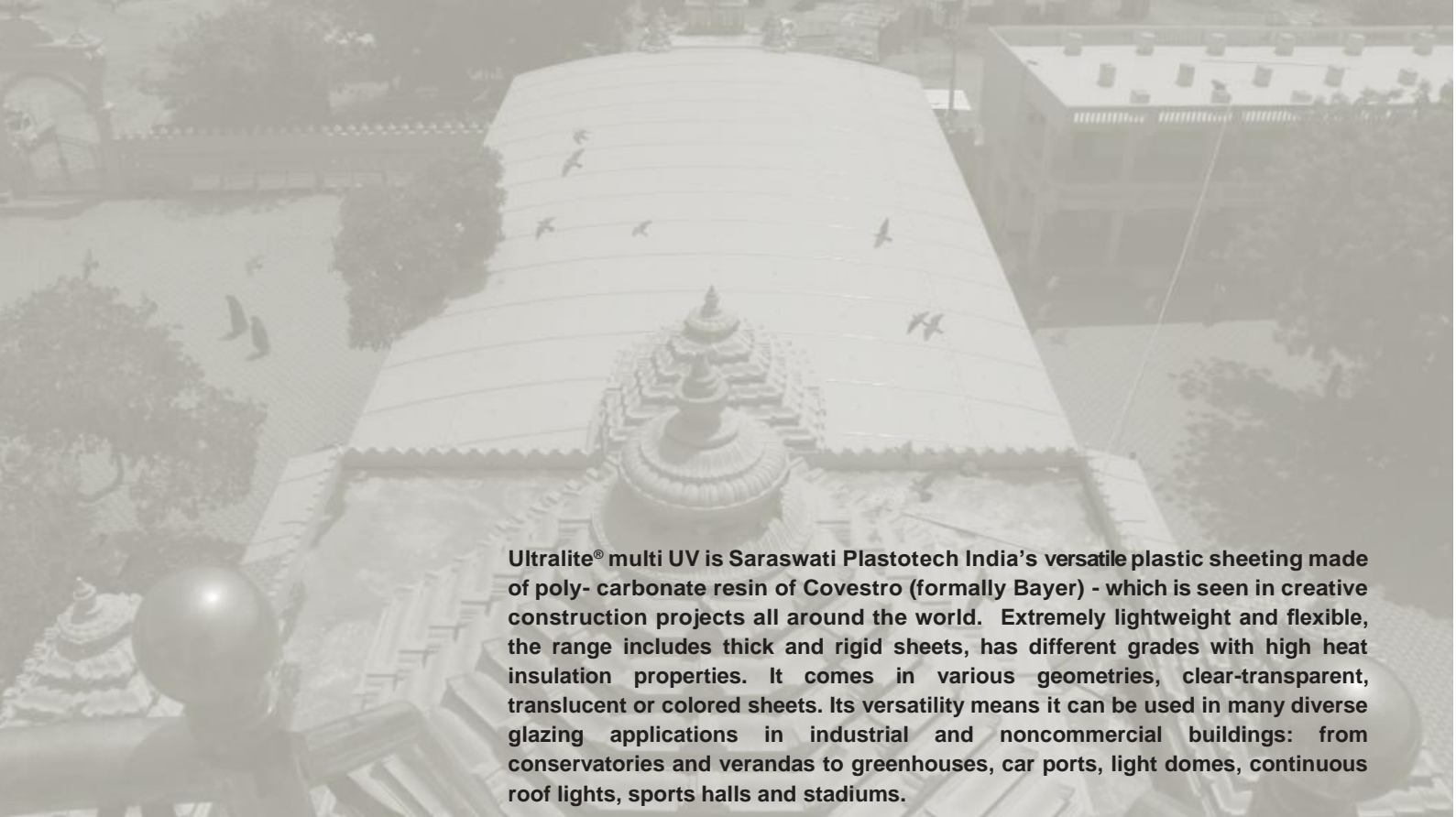

Ultralite® multi UV is Saraswati Plastotech India's versatile plastic sheeting made of poly- carbonate resin of Covestro (formally Bayer) - which is seen in creative construction projects all around the world. Extremely lightweight and flexible, the range includes thick and rigid sheets, has different grades with high heat insulation properties. It comes in various geometries, clear-transparent, translucent or colored sheets. Its versatility means it can be used in many diverse glazing applications in industrial and noncommercial buildings: from conservatories and verandas to greenhouses, car ports, light domes, continuous roof lights, sports halls and stadiums.

THE POLYCARBONATE MULTI



1. AT A GLANCE TECHNICAL SPECIFICATION

Each grade designation shows the profile, colour, light transmission and additional properties of Ultralite® multi UV sheeting.

Example:

Ultralite® Multi UV	5M/25-20	white
Brand name	Geometry	Colour
Ultralite® Multi UV	1st digit: layers	Clear
	2: twin wall	white
	3: triple wall	bronze
	4: 4-wall	green
	5: 5-wall	blue
	6: 6-wall	
	Optional: structure	
	M: M-structure	
	2nd digit: thickness	
	e.g. 25: 25 mm thick	
	3rd digit: rib distance	
	e. g. 20: 20 mm	

Grade Classification

- GP- General purpose
- UV- UV protected
- UV1- Anti UV protected one side
- UV2- Anti UV protected both side

WALL SHEET

2. WARRANTY

Ultralite® multi UV comes with a ten-year warranty against weathering and hail. Its longevity is down to its protective coextruded layer, our stringent quality control on the raw materials used, and the quality of the production process. Artificial and natural weathering tests have shown that the sheets still have an excellent performance after ten years, even under extreme climatic conditions.

A detailed warranty statement is available from your distributor or on our website or Contact our local representative



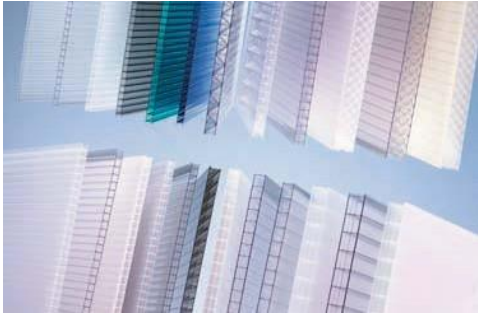

■ STANDARD PRODUCT RANGE

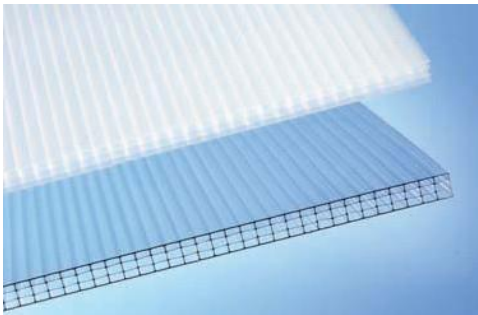

Our commitment to continuous product development means there are always new and improved products in the pipeline. For special applications, such as stadiums, sheets with higher load bearing characteristics and with a higher weight per m² are available on request. Sheets with different colours and different transmission values are also available on request.

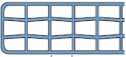

The diagrams in the chapter statics can help you determine which sheet type is best suited for your application

PROFILE	GRADE	THICKNESS IN MM	HEIGHT IN KG/M ²	WIDTH IN MM	COLOURS	U _g -VALUE W/M ² K	DESCRIPTION
	2/4	4	0.80	2,100	CLEAR - WHITE	4.1	MULTI UV 2/4-6
	2/6	6	1.30	2,100	CLEAR - WHITE - BRONZE	3.6	MULTI UV 2/6-6
	2/8	8	1.50	2,100	CLEAR - WHITE - BRONZE	3.3	MULTI UV 2/8-10.5
	2/10	10	1.60	2,100	CLEAR - WHITE - BRONZE BLUE - GREEN	3.1	MULTI UV 2/10-10.5
	4/8	8	1.60	2,100	CLEAR	2.66	MULTI UV 4/8-6
	4/10	10	1.65	1,200 2,100	CLEAR - WHITE	2.5	MULTI UV 4/10-6
	3/16	16	2.80	980 1,200 2,100	CLEAR - WHITE - BRONZE	2.4	MULTI UV 3/16-16
	5M/25	25	3.50	980 1,200	CLEAR - WHITE	1.6	MULTI UV 5M/25-25
	5M/32	32	3.60	980 1,200 1,230	CLEAR - WHITE	1.4	MULTI UV 5M/32-25
	5M/40	40	4.20	980 1,200 1,230	CLEAR - WHITE	1.2	MULTI UV 5M/40-25

■ MATERIAL PROPERTIES



Ultralite® is synonymous with first-class sheets. They are made from polycarbonate and available in solid (GP & UV) and multi-wall (multi) format. Their versatility is such that they can be used in many applications and can withstand a large temperature range.

Ultralite® sheets are renowned for good transparency, extremely high break resistance and impact strength, high dimensional behavior stability and good electric insulation. They also obtain excellent fire ratings (see the specific datasheets for more detailed information).

Their consistency is thanks to outstanding raw materials from Covestro (Formally Bayer)

	Test Conditions	Typ. Values	Unit	Test Method
Physical				
Density		1.2	g/cm ³	ISO 1183-1
Moisture absorption	after storage in standard climate 24h/23°C/50% RH	0.15	%	ISO 62-4
Moisture absorption	after storage in water at 23°C until saturation	0.35	%	ISO 62-1
Refractive index	20°C	1.586	-	ISO 489
Mechanical				
Tensile stress at yield		> 60	MPa	ISO 527-2/1B/50
Elongation at yield		6	%	ISO 527-2/1B/50
Tensile strength		> 60	MPa	ISO 527-2/1B/50
Elongation at break		> 70	%	ISO 527-2/1B/50
Elastic modulus		2400	MPa	ISO 527-2/1B/1
Limiting flexural stress		ca. 90	MPa	ISO 178
Impact strength	Charpy, unnotched	no break	kJ/m ²	ISO 179/1fU
	Charpy, notched	ca. 11	kJ/m ²	ISO 179/1eA
	Izod, notched	ca. 10	kJ/m ²	ISO 180/1A
	Izod, notched (*)	ca. 70	kJ/m ²	ISO 180/4A
Thermal				
Vicat softening temperature	Method B50	148	°C	ISO 306
Thermal conductivity		0.2	W/m ² K	DIN 52612
Coeff. of linear thermal expansion		0.065	mm/m-°C	DIN 53752-A
Heat deflection temperature under load	Method A: 1.80 MPa	127	°C	ISO 75-2
	Method B: 0.45 MPa	139	°C	ISO 75-2

The mechanical properties were measured on solid sheets of 4 mm or 3 mm thick

CHARACTERISTICS

1. IMPACT STRENGTH

Hail impact

Ultralite® outperforms most other transparent materials on impact strength. Ultralite® multi UV sheets provide guaranteed protection against hailstones, due to the material's high impact resistance. This is why, all Ultralite® multi UV sheets have a 10-year limited warranty on weathering and hail resistance.

These outstanding properties have been proven in repeated hail simulation tests. In tests, pellets of 6.6 polyamide with a diameter of 20 mm (weight approx. 4.5 g) are shot at room temperature against the weathered surface of a sheet at a speed of 21 m/s, equivalent to a kinetic energy of 1 joule.

According to expertise, a natural hailstone of 23 mm in diameter has an average impact velocity of 17 m/s and a kinetic energy of 1 joule. However, a hailstone study has concluded that the chances of experiencing hailstones of more than 10 mm in diameter in, for example, the Stuttgart area (Germany), are only around 2.9%. Hailstones of a greater diameter are even less frequent.

For detailed information on our warranty, please check our warranty statement, available at our distributors and on our website.



Ball impact in sports

Ultralite® multi wall sheets have been tested for resistance to ball impact and the results show that they are suitable for sports hall glazing. All the Ultralite® multi UV sheets which underwent testing, withstood the impact of handballs and hockey balls. The results are listed in the table below.

The excellent impact resistance of these sheets also gives the assurance that they will not be damaged by other hazards such as nuts falling from a tree.

Ultralite® multi UV	Test	Result
3/16-16	DIN 18032, part 3 (handball & hockey ball)	passed



■ CHARACTERISTICS

2. LIGHT WEIGHT

With area weights of 0.8 to 4.2 kg/m² Ultralite® multi UV sheets are notably light weight. They have been designed to offer optimal load-bearing characteristics at minimal weight. In roof glazing, for example, no massive supporting construction is necessary, which enables light and open constructions.

For special applications, such as stadiums, sheets with higher load bearing characteristics and higher weight per m² are available on request.



3. WEATHERING RESISTANCE

Ultralite® multi UV sheets are extremely weather-resistant because the sheets are produced with a coextruded UV-protective layer. This layer comprises the same basic material as the sheet material and is homogeneously fused with it. No delamination of the layer is possible, even after years of exposure to the elements or if the sheets are cold bended. The UV-protected side must be installed facing upwards/outwards.

This system has been extensively tested both in artificial weathering tests as well as in natural weathering under extreme climatic conditions. It provides Ultralite® multi UV with a highly effective protection against weathering, guaranteed for 10 years.

For detailed information on our warranty, please check our warranty statement. This document is available at our distributors place or with our company executives.



CHARACTERISTICS

4. THERMAL INSULATION

Ultralite® multi UV sheets offer much better heat insulation than single glazing, because of their special multi wall structure and low heat conductivity. This is measured as the U-value and depends on the number of chambers and the thickness of the air cushion: the more chambers and the thicker the air cushion, the lower the U-value.

In recent years, SPT has continued to develop sheets with improved thermal insulation. This helps reduce the CO₂ outputs associated with global warming. This has resulted in several new types, such as 4-wall, 5M-thick wall sheets, which have lower U_g values than other sheets of the same thickness.

See the individual data sheets for more details or the table in previous pages



5. LIGHT TRANSMISSION

Ultralite® multi UV sheets have a light transmission value of up to 81%, depending on the structure, colour and thickness of the sheet (check the individual data sheets for more details). Ultralite® multi sheets are structured such that the transmitted light is dispersed homogeneously, preventing unpleasant light spots and hot spots.

Coloured and/or translucent sheets reduce light intensity and heat, which results in pleasant room climate and ambience. Our newly developed opal white sheets (46 % Lt transmission) offer improved light transmission, resulting in a more diffuse but brighter light, ideal for working environments.

Ultralite® multi opal white (special new development in request) sheets, which dramatically reduce heat from sunlight, whilst allowing visible light to pass through. Real-life tests in unventilated conservatories have shown remarkable heat reduction of up to 12°C compared with standard sheets. This guarantees comfortable room temperatures regardless of the weather. More light, less heat!

Ultralite® multi UV sheets absorb dangerous UV radiation (under 400 nm). These sheets are therefore ideal as continuous roof lights or in situations where protective glazing is needed to shelter materials sensitive to UV-light in factory units, museums or shopping centres.

However, plant growth is not negatively influenced by Ultralite® multi UV sheets, as they transmit the relevant light spectrum (PAR = photo active radiation). This important property means the sheets are well suited for applications such as greenhouses or football stadiums.

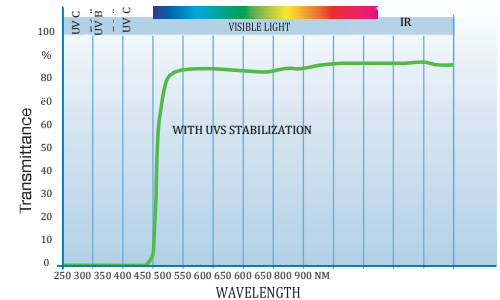

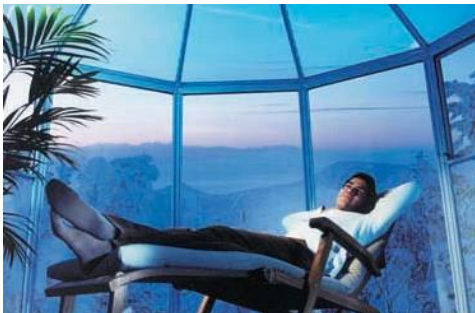

6. SOLAR TRANSMISSION

Sunlight is made up of visible light, UV-light and infra-red light. The infra-red light, which is invisible, is responsible for transferring heat from sunlight. The solar transmission shows the amount of heat transmitted by the sheet. This is expressed by the total energy transmission g; the lower the g-value, the less heat transmitted by the sheet, and the lower the heat build-up in the building.

Coloured sheets have a lower g-value, usually in line with their light transmission. Ultralite® multi UV white special sheets have energy selective properties: they allow as much visible light as possible, while simultaneously reducing the g-value, resulting in more light and less heat. (see also p. 5)

Typical values of light transmission and solar heat transmission are shown below:

	light transmission at D65	total energy transmission g
Ultralite® multi UV 2/6-6 clear white	ca. 79% ca. 77%	
Ultralite® multi UV 2/8-10.5 clear White	ca. 81% ca. 78%	
Ultralite® multi UV 4/8-6 clear	ca. 68%	ca. 64%
Ultralite® multi UV 2/10- 10.5 clear white SP White	ca. 80% ca. 70% ca. 70%	ca. 74% ca. 68% ca. 58%

	light transmission tauD65	total energy transmission g
Ultralite® multi UV 4/10-6 clear white SP white	ca. 68% ca. 61% ca. 52%	ca. 64% ca. 60% ca. 47%
Ultralite® multi UV 3/16-16 clear white bronze	ca. 74% ca. 56% ca. 46%	ca. 67% ca. 58% ca. 50%
Ultralite® multi UV 3X16-25 clear white SP white	ca. 66% ca. 54% ca. 50%	ca. 61% ca. 53% ca. 40%
Ultralite® multi UV 6/16-20 clear white SP White	ca. 59% ca. 49% ca. 40%	ca. 56% ca. 50% ca. 37%
Ultralite® multi UV 6/20-20 clear White	ca. 58% ca. 52%	ca. 56% ca. 48%
Ultralite® multi UV 5X/25-25 clear white SP White	ca. 54% ca. 40% ca. 37%	ca. 50% ca. 42% ca. 34%
Ultralite® multi UV 5X/32-25 clear white SP white	ca. 54% ca. 39% ca. 40%	ca. 50% ca. 43% ca. 35%
Ultralite® multi UV 5X/40-25 clear white SP White	ca. 54% ca. 38% ca. 33%	ca. 54% ca. 44% ca. 33%



CHARACTERISTICS

7. FIRE BEHAVIOUR

Ultralite® multi UV sheets meet the stringent quality standards set by many different countries in the area of fire safety. In realistic large-scale fire tests, Ultralite® multi UV sheets have been rated as a flame-retarded construction material. This means that the material does not cause flame propagation, but it cannot be considered as a fireproof material.

Its self-extinguishing properties, low area weight and structure allow the sheet to soften in the event of fire. It then tears open and shrinks back from the fire source without spreading the fire itself. Smoke and heat dissipate through the opening which is formed, thus leading to a drastic temperature reduction in the room and, more critically, reduced load on the supporting structure. In effect, the sheet is acting as a heat extractor. Heat extractors relieve the thermal load on a building in temperatures of 300 °C or more in a fully developed and growing fire. The benefit is prolonged fire resistance.

The use of Ultralite® reduces the thermal load on the building and the fire resistance required of building components. This needs to be evaluated with fire safety engineering methods as part of an overall fire safety concept for a specific building. Remember also to check local regulations to see such a construction is allowed.



■ CHARACTERISTICS

8. SMOKE BEHAVIOUR

The tests for classifying building products mainly determine the primary burning characteristics - ignitability and spread of flame. However, smoke evolution and its effects are also important for risk assessment.

The most crucial aspect in assessing smoke gas evolution is the phase of the fire and the risk situation in which the smoke development is detected. Conditions change markedly as a fire develops. If people are present in the burning room, smoke gas toxicity is likely to be significant only in the development phase of the fire. It is no longer decisive in a room that is already in a full-scale blaze with temperatures above 500°C.



combustion Ultralite® does NOT produce hydrogen cyanide, phosgene, acrolein, hydrogen chloride or sulphur dioxide. Combustion products are essentially non-corrosive. On the whole it may be stated that the toxicity of these combustion gases is determined largely by the toxic effect of carbon monoxide, and that the contribution of other constituents is much less important. In fires the combustion gases of Ultralite® comprise mainly carbon dioxide, carbon monoxide and water. In some cases, minor quantities of subsidiary constituents may be released: aliphatic and aromatic hydrocarbons, aldehydes, acids and phenol derivatives. During

CHARACTERISTICS

9. TEMPERATURE RESISTANCE

Ultralite® multi UV sheets can be used at temperatures between -100 °C up to +120°C. The stability of the sheets remains at a high level within this temperature range. Due to this, the sheets can be used where other plastics will fail.

In normal circumstances, the temperatures to which the sheets are exposed will be in the range of -15 °C up to +60 °C, which is well within the material's tolerances.

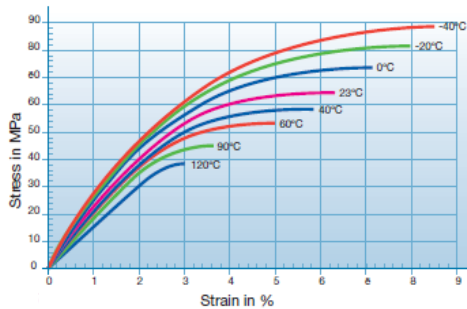

Tensile stress of Ultralite® in relation to the temperature



10. NOISE INSULATION

Ultralite® multi sheets have useful noise insulation benefits. They have to be regarded as single-shell elements, because of the rigidity of their layers. All Ultralite® multi products are tested to ISO 140/3 at ARAI. Depending on the sheet type, typical sound reduction values in the range of 10 to 21 dB can be reached. The weighted sound reduction index is stated in the individual product data sheets.

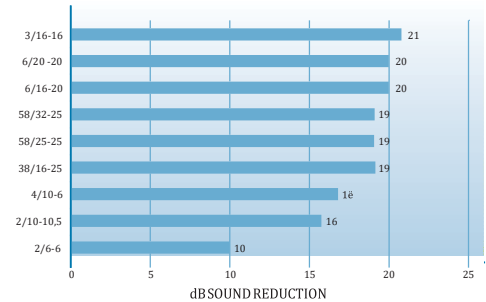

Estimated Weighted sound reduction index of the different sheets.

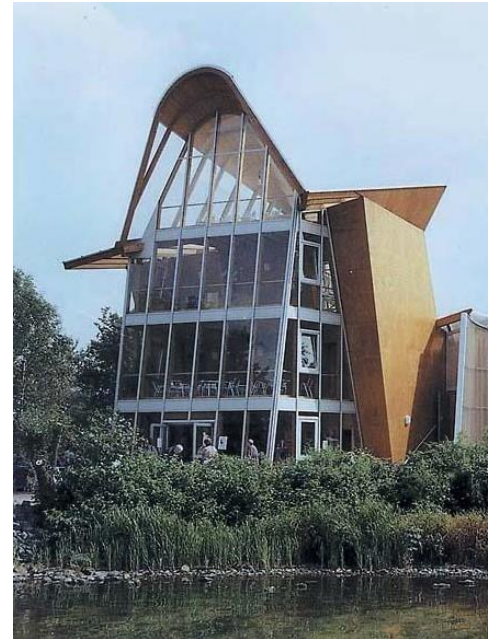

■ CHARACTERISTICS



11. CHEMICAL RESISTANCE

Ultralite® multi UV sheets can, like other plastics, be affected by certain substances. In order to avoid hairline cracks, only compatible clamping bars, seals and cleaning agents may be used. Contact with plasticized PVC, cement, thinners, insecticide sprays, impregnating agents, strong industrial cleaning agents and other corrosive solvents must be avoided at all times. Also avoid alkaline, ammonia-based or acetic-based sealing materials and use neutral systems instead. Suitable sealant systems are available - please ask your sheet supplier.

Due to the risk of stress cracking, no vapours must be allowed to filter into the sheet cavities. Follow this advice very closely, since most problems arise from using unsuitable and non-recommended auxiliary products.

It's important to remember that contact with non-compatible products can happen not just with the installation equipment or during the construction of the building. It can also happen afterwards, as a result of emissions emanating from the installation production processes or nearby. If in doubt, please contact our technical service.

As a general guideline on the chemical resistance of Ultralite®, we can state as follows:

Polycarbonate

resists:

- mineral acids up to higher concentrations
- neutral and acidic salt solutions
- oxidizing and reducing agents
- saturated, aliphatic hydrocarbons and alcohol with the exception of methanol (methyl alcohol)
- many oils, fats, waxes

is damaged by:

- alkali
- ammonia and amines, as well as their solutions
- aromatic or halogenated solvents
- aldehydes, ketones and esters
- methyl alcohol



■ TRANSPORT AND STORAGE

1. TRANSPORT AND HANDLING

Ultralite® multi UV multiwall polycarbonate sheets are light weight and as a result easy and safe to handle in warehouses and on building yards. However, some details must be taken into account in order to avoid damage to the sheets and help towards a successful installation.

For the handling of standard size pallets, lift trucks which accommodate the pallet width (2100 mm max.) and length (6 to 7 m) are recommended. In some projects, sheets of at least 12m are used – often longer than the pallet supporting them.

We recommend taking the following precautions:

- Prevent the pallet from flexing when lifting it with a crane. Use adequate lifting methods to prevent the pallet breaking and to avoid any protruding pallet nails.
- The cables must be tightened in such a way that they don't harm the sheet packaging. A suitable upper rocker arm, on which the lifting hook is to be linked, must be prearranged.
- When the package is laid on the ground, the sheet ends will hang down. They must be adequately supported to avoid contact with the ground.

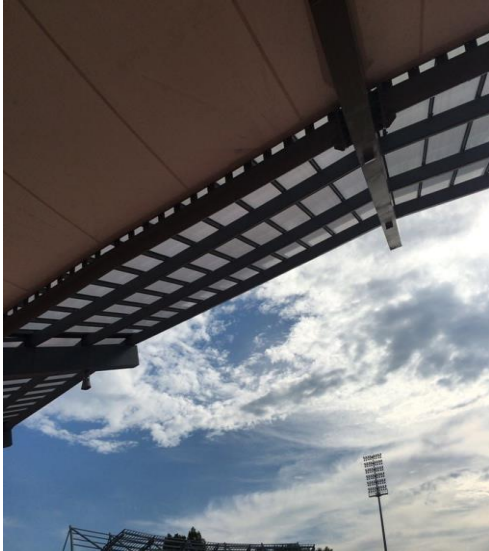

2. STORAGE

The best way of storing the sheets is to keep them indoors in a horizontal position. During production, protective tape is applied to the edges of the sheets to protect the cavities. It prevents dust - attracted by electrostatic charges on the sheet - from settling. The tape must stay on the sheet during transport and storage, but must be removed before installation and be replaced by a suitable sealing system.

Ultralite® multi UV sheets can be stored outside if necessary. Make sure the sheets are still protected by the polyethylene wrapping as with the delivery. The wrapping must be intact and well fixed, even if some of the contents have already been used.

However, it is better to limit outdoor storage: whilst the wrapping protects the sheets from rain, it is not completely vapourproof. This may, under certain conditions (for example a sudden cooling after a long period of wet heat), lead to the formation of condensation inside the cavities.

All sheets are covered with protective masking prior to delivery. Long outdoor storage under high temperature, or direct sunlight, can make the masking too sticky, and removal after installation can then be very difficult or even impossible.

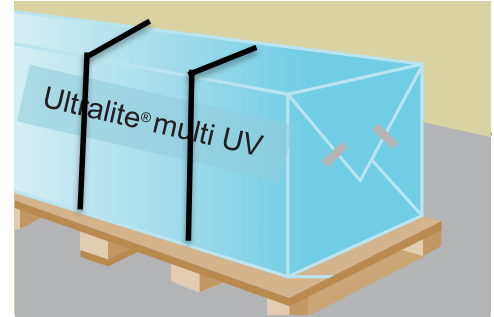

Typical packaging of Ultralite® multi UV sheets with polyethylene wrapping

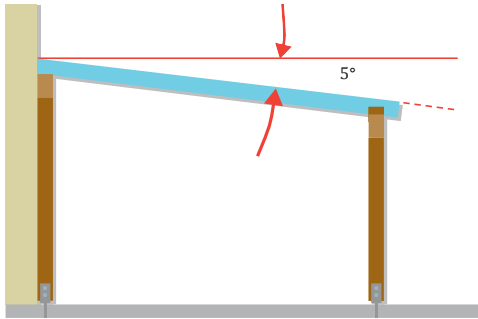

*Recommended angle of inclination for sheets
lengths up to 6 m*

■ INSTALLATION

1. INSTALLATION CONSIDERATIONS

Flat glazing

If Ultralite® multi sheets are employed as roof or wall elements, we advise installing them in such a way that the ribs are parallel to the direction of the water flow.

The large sheet lengths means installation is almost always possible without butt joints. For roofing up to a length of 6m, the pitch should be at least 5°. In practice, that means a pitch of approx. 90mm per meter of sheet length. This ensures that rainwater flows off readily and that a good self-cleaning effect is achieved due to the smooth surface of Ultralite® sheet. Larger roofs should be built with a higher angle (>90mm/m).

The potential sheet length (unsupported span) depends on several parameters, such as: the load bearing characteristics of the sheet, spacing of the purlins and expected wind or snow loads.

The tables as of static chapter pages take all these parameters into consideration and can be used as a guideline to determine the construction design.

Curved glazing

Ultralite® multi sheets are ideal for arched structures such as barrel vaults and tunnel greenhouses. The sheets have to be bent in the direction of the ribs, never the other way. There is no need to heat them (cold curving). Curving the sheets increases the rigidity of the sheet.

We recommend clamping the sheets on all four sides to achieve maximum load bearing capacity.

The spacing of the hoops depends on the load bearing characteristics of the sheets, the maximum assumed load and the chosen bending radius. For load bearing calculation of curved glazing applications, please contact our Technical Department.

The following table lists the minimum curving radii. Please bear in mind that the smallest permissible radius is stated for each sheet type. In order to avoid excessive sheet stress, lower values must be avoided.

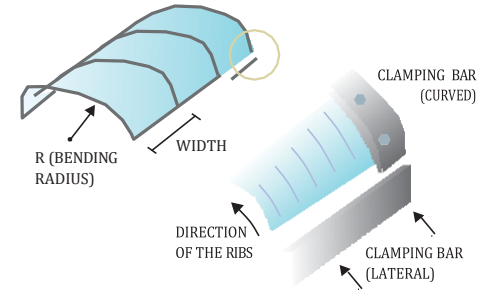

Ultralite® multi UV	Min. cold bending radius in mm
2/4-6	700
2/6-6	900
2/8-10.5	1200
4/8-6	
2/10-10.5	1500
4/10-6	
3/16-16	2400
3/16-25	3000
5M/25-25	not recommended
5M/32-25	
5M/40-25	

■ INSTALLATION

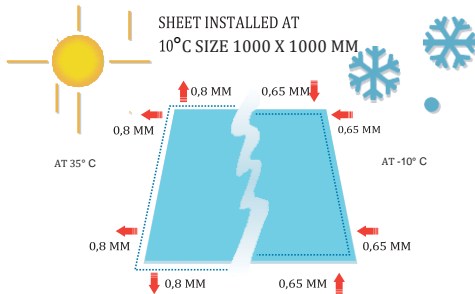

Thermal expansion.

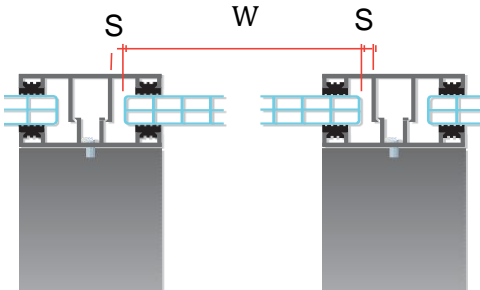

Expansion in width

Thermal expansion

Ultralite® multi UV sheets expand when heated and contract when cooling. The

linear thermal expansion coefficient of polycarbonate is:

$$\alpha = 0.065 \text{ mm/m-}^\circ\text{C} = 6.5 \cdot 10^{-2} \text{ mm/m-}^\circ\text{C}$$

As with most polymers, this thermal expansion coefficient is much higher than other materials (about 8 times higher than glass, 6 times higher than steel and 4 times higher than aluminum). This movement can sometimes cause a creaking noise, but it does not compromise the functional effectiveness of the sheet.

For this reason, all fastening and clamping devices must be fashioned to allow sufficient room for expansion and shrinkage.

- If the sheet edge touches the inner part of the profile and the temperature increases, the sheet will not be able to expand. The sheet will distort or, in extreme cases, get damaged.
- If the sheet is installed with the edge too close to the outer extremity of the profile, the sheet could slip out of the support frame when it shrinks during cold winter weather. This effect can be reinforced by other factors such as snow load.
- The design of rubber joints must allow for significant expansion and shrinkage to prevent the joints coming out of the profiles or damaging the sheet.

Calculation example:

Sheet size: 1000 x 3000 mm (1 x 3 m)

Expected highest temperature: 35° C

Expected lowest temperature: -10° C

Temperature difference ΔT : 45° C

Expansion in width: $\alpha \cdot \Delta T \cdot W = 0.065 \text{ mm/m-}^\circ\text{C} \cdot 45^\circ \text{ C} \cdot 1 \text{ m} = 2.92$

Expansion in length: $\alpha \cdot \Delta T \cdot L = 0.065 \text{ mm/m-}^\circ\text{C} \cdot 45^\circ \text{ C} \cdot 3 \text{ m} = 8.77 \text{ mm}$

We recommend allowing for expansion of 3 mm/m.

E = maximum clearance in mm between the lower stop and the upper limit.

A = length in mm added by the lower edge closure section
(if also used at the upper end, add to A)

ΔL = longitudinal tolerance according to sales range

S = allowance for expansion (3 mm/m for Ultralite® multi UV).

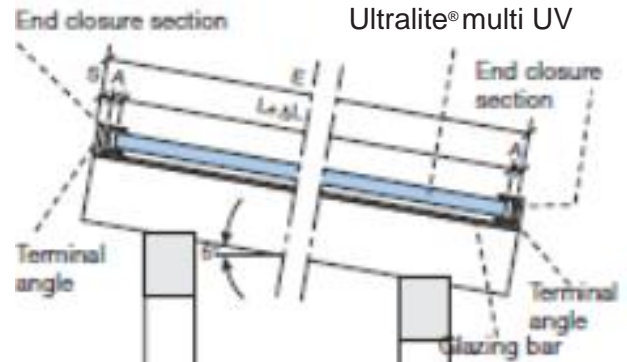

Allowance for expansion in length

■ INSTALLATION

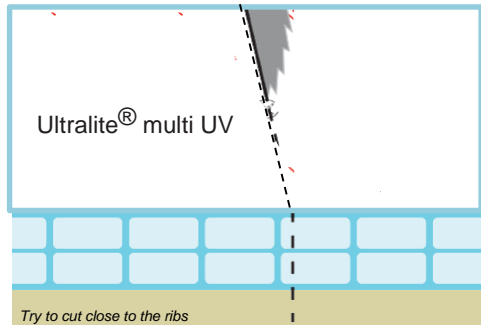
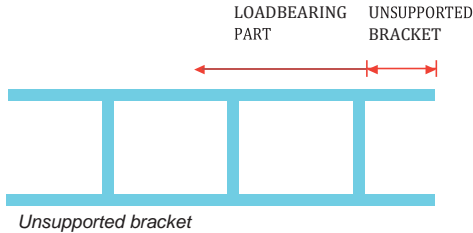

Rabbet depth design

For a proper installation of Ultralite® multi UV sheets the clamping profiles must have a correct rabbet depth design. There are various aspects to be considered:

- The difference in thermal expansion between the sheets and the profiles must be taken into account (see previous chapter).
- As Ultralite® is a plastic material, it will flex slightly when subjected to pressure from external loads. Even though the sheets are very rigid, this causes a virtual shortening of the dimensions of the sheet. All Ultralite® multi UV sheets have been tested for load bearing capability in real life tests (see chapter 7). When the rabbet depth on both sides of the sheets is calculated according to the expected temperature variations (with a minimum of 20 mm) and the tables in chapter 7 are used to determine the sheet dimensions, you do not need to make any further calculations to account for the virtual shortening as we have already allowed for this.
- When Ultralite® multi UV sheets are cut longitudinally (i.e. the cut is made parallel to the direction of the ribs), there may be some unsupported brackets. These use up some mm of rabbet depth, but do not contribute to the load bearing capacity of the sheet. For safety reasons calculate the rabbet depth starting at the first closed rib.

Surface direction

One side of the Ultralite® multi UV sheets has a UV-protective layer which is applied by coextrusion and is homogeneously fused with the sheet.

Important: Always install the sheet with the UV side facing upwards/outwards, i.e. turned towards the sun! This UV side is masked with a clear, printed protective film as a standard feature. The UV side can also be identified by the imprint applied by ink-jet along the edge of the sheet.

Our warranty statements only apply if the sheets have been installed correctly.

Sheets with a UV protection on both sides can be delivered, if requested. Some sheet types are available with a 'no drop' coating on the other side of the UV-protected surface. These sheets must be installed with this coating facing inwards/inside. The 'no drop' functional layer is covered with a protective film. This film can be removed by washing with clear water or it will come off automatically after a while due to condensation on the sheet. The 'no drop layer' is only fully activated once the protective layer has been completely washed off.

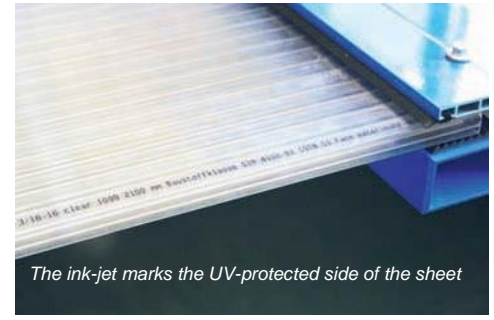

The ink-jet marks the UV-protected side of the sheet

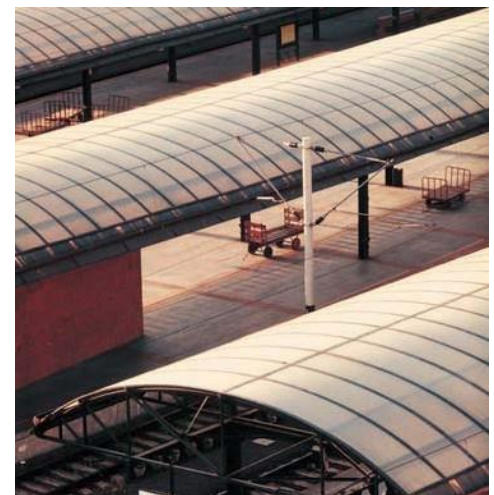

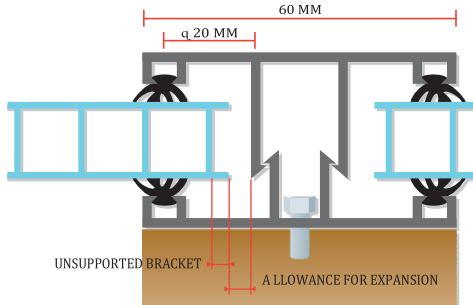

Rabet depth design.

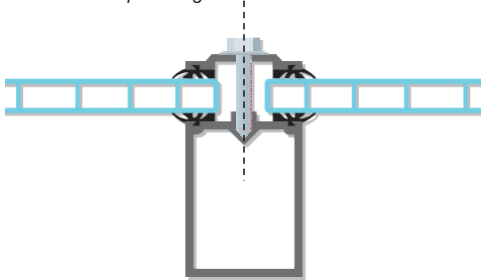

Profile system with preset clamping pressure

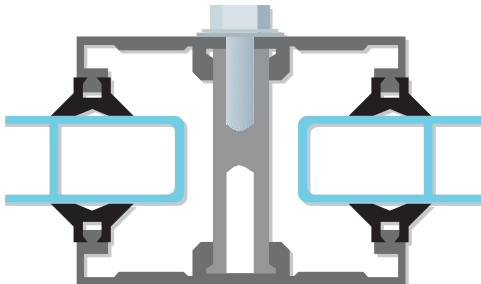

Distance ring

■ INSTALLATION

2. CONSTRUCTION DETAILS

Profiles

Many different profiles are available, from single profiles to fully modular mounting systems. Aluminium profiles with EPDM rubbers are most commonly used with multi wall sheets. In practice every classical construction is possible as long as the specific characteristics of polycarbonate are respected.

To fulfil the requirements for optimum load characteristics it is important that all the edges are properly clamped with a rabet depth of at least 20 mm, with at least one rib of the sheet located in the clamping area.

Any gaskets used must be chemically compatible with polycarbonate (see also p. 26) and care must be taken not to stress the sheets during the construction. In all glazing systems with Ultralite® multi UV, the contact pressure exerted on the sheet by the glazing bead or clamping plate is important. This pressure is transmitted to the sheet via the glazing gasket or seal. The pressure must be regulated and uniform to ensure an adequate weather seal. Excessive contact pressure will adversely affect the glazing gasket or seal. Since the glazing gasket is the softest part in the glazing system, excessive contact pressure will cause it to bulge, or even be displaced from the glazing system which will then no longer be watertight.

We recommend using a distance ring or a profile system in which the clamping pressure is preset by the design.

Gasket and seals

For Ultralite® multi UV to remain waterproof, the gasket used in the glazing system must be resilient yet still allow for the predicted expansion and contraction of the sheet. To achieve weather tightness the gasket must be the right shape and be made of the right material.

The material from which the gasket is manufactured must be compatible with Ultralite®. The following materials are likely to be compatible:

- EPDM
- Polychloroprene
- Polyethylene (PE)
- PTFE
- Neoprene
- Silicone
- EPT

The following materials are usually not compatible:

- PVC
- PVC/Nitrile
- Polyurethane (PU)



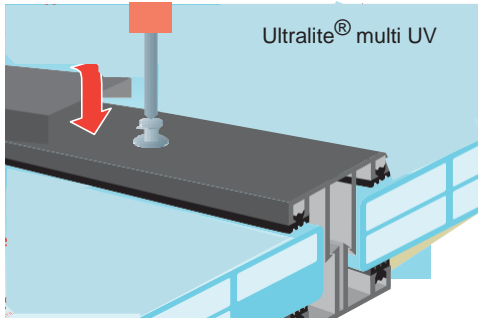

Adjusting the contact pressure on the sheet.

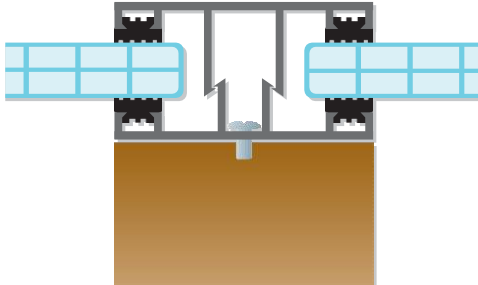

Typical profile systems and gaskets

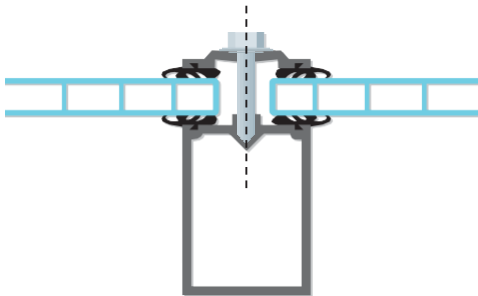

Too much pressure must be avoided

■ INSTALLATION

In general, gaskets must be tested for compatibility before being incorporated into glazing systems for use with Ultralite®.

Because of sheet movement caused by expansion and contraction, gaskets must be mechanically secured to the glazing system or they will become dislodged. Securing by adhesion is not adequate.

In all Ultralite® glazing systems, the contact pressure exerted on the sheet by the glazing bead or clamping plate is important. This pressure is transmitted to the sheet via the glazing gasket or seal. The pressure must be regulated to be sufficient to ensure an adequate weather seal. However too much pressure can also shorten the life of the seal. We recommend using a distance ring or profile systems in which the clamping pressure is preset by the design.

Additional support systems

In some constructions the sheets will not only be clamped at the edges, but they will have an additional support. For instance, if a 6 m roof is required and the calculations advise a maximum unsupported span of 3 m it is possible to either install 2 sheets of 3 m or 1 sheet of 6 m with an additional support structure in the middle.

Be aware that loads on the sheet can act in both directions: a snow load typically exerts a downward pressure. Wind can create downward or upward pressure or depression. Additional support structures must be effective for any eventuality: just placing an additional purlin under the sheet will not be sufficient.

There are two possible solutions:

1. Perforating the sheet and using special 'buttons' to fix the sheet to the purlin underneath. These buttons must have a gasket that makes an effective seal and a form that prevents over-tightening, which would cause the sheet to deform.

Please take into account:

- Fixing buttons can only be used for flat glazing applications, otherwise a good seal won't be possible.
- The hole in the sheet must be oversized to allow for thermal expansion of the sheet (3 mm/m sheet length).
The hole must be at least 50 mm from the edges of the sheet.

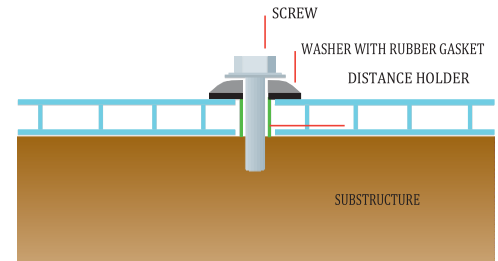

fixing buttons.



■ INSTALLATION

- Perforation of the support underneath will produce shavings which could remain inside the sheet. If made from conventional steel (not stainless steel) be aware that these shavings could oxidize and create rusty stains in the sheet.

In general, fixing buttons are only advisable if you don't require a perfect visual appearance.

2. Structures required to push the sheet against the support underneath as part of the load bearing framework will have to be designed by a suitably qualified structural designer.

Also in this case, some considerations could be useful for the designer:

- It is important to consider placing suitable plastic materials between the sheet and the sheet-pusher in order to avoid direct contact between the polycarbonate and the steel.
- The form and the dimension of these accessories will have to be such that they don't hinder the flow of rainwater.

As this second solution is more difficult to accomplish, it is usually only applied in special projects.

3. PREPARATIONS FOR INSTALLATION

Cutting

Ultralite® multi UV sheets are most easily cut with a sharp knife.

Sheets with a compact structure or with thick outer skins can be cut with fine-toothed handsaws, circular saws, band saws or other types of saws. Make sure the saw is new and the blade very sharp.

In particular, our advice is to:

- leave the protective masking on the sheet whenever possible during sawing;
- mark the desired cut with a soft pencil only;
- work with a stop or a guide;
- make sure the sheet is placed on a firm support;
- work at a cutting speed of approx. 50 m/sec with continuous feed;
- use jigsaws without stroke action for curved cuts and recesses;
- remove swarf by vacuum or blowing down with oil-free compressed air;
- follow the relevant safety regulations;
- when cutting with a knife, use blades that are short and rigid.

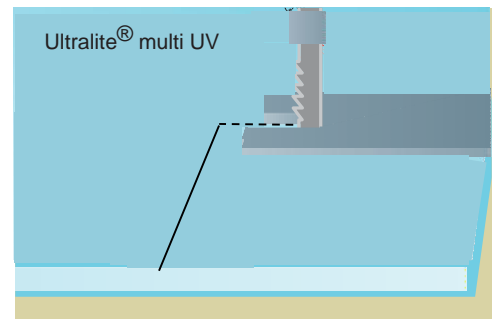
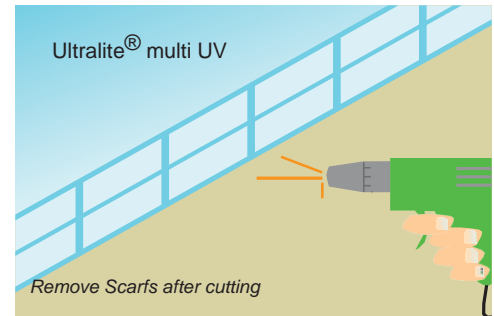
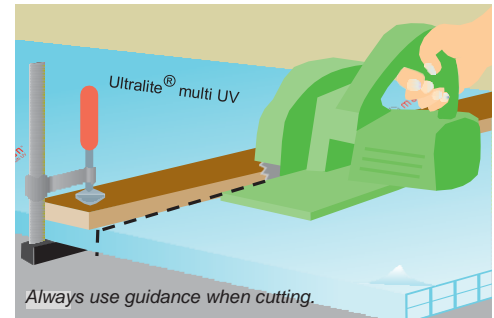

■ INSTALLATION

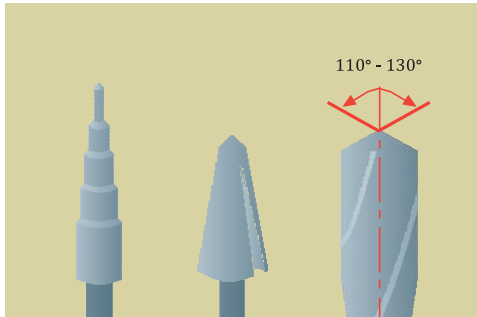

Typical drills.

Drilling

If you need to drill holes in Ultralite® multi UV, you may use drills suitable for metal-working.

For best results, we advise you to:

- use tube and sheet drills normally used for working sheet metal;
- make sure the sheet is placed on a firm support;
- try to drill holes with clean edges;
- work at moderate pressure to prevent splitting when perforating the sheet;
- always work with sharp drills!

Sealing the open ends of the sheets

The open ends of Ultralite® multi UV multi wall sheets are sealed at our factory with protective tape for transportation and storage purposes. For durable installation, it is advisable to remove this transport tape and to seal the sheets with weather-resistant adhesive tape, e.g. aluminum tape. Use only suitable products.

There is a simple but very important rule for closing the open ends of the sheets: as tight as possible at the top and as tight as necessary at the bottom.

To allow the chambers to ventilate and keep spores out we recommend using ventilating tape with about 50µ pores at the bottom and an impermeable (aluminum) sealing tape on the top. After taping, push on an aluminum end closing section at both ends. This largely prevents the infiltration of dirt, insects and water, while allowing air to circulate inside the sheet and condensation to evaporate or drain off.

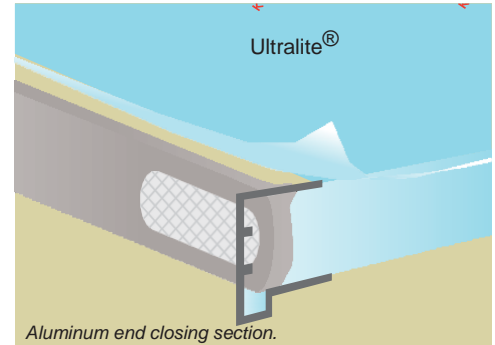
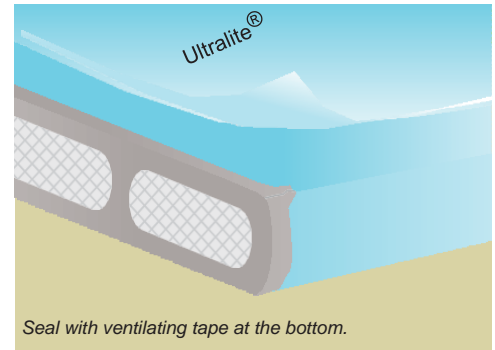

■ INSTALLATION

The tape itself should have a good weathering and tearing resistance and no loss of long term adhesion or mechanical strength. Be sure that all sheet edges are smooth and rounded before applying the tape, so the tape will not be punctured. Sealing tapes for Ultralite® multi UV sheets are available at most distributors and specialized installers. Since plastics are permeable to water vapour, condensation may occur even in multi wall glazing elements such as Ultralite® multi wall sheets. It is therefore important that Ultralite® multi UV sheets are always mounted with the ribs running downwards to assist the drainage of condensation water.

When mounting the sheets into the glazing profiles it is important to make sure that the tape is not damaged and that the profiles cover the tape completely. Replace damaged tape if necessary.



Removing the masking

The surfaces of Ultralite® multi UV sheets are protected during transportation, storage and installation by self-adhesive PE masking film. This masking does not cover the edges of the sheets. This is to enable installation while the protective masking is still on the sheet and to enable removal of the masking after installation.

In general, all films should be removed straight after installation especially if the sheets are exposed to weathering, otherwise the films risk becoming brittle or more adhesive. If this happens the film cannot be removed correctly and damage to the sheets can no longer be ruled out.

Safety

Roofs covered with Ultralite® multi UV cannot be walked on.
Always use supports to walk on the roof. Never walk on structures which incorporate Ultralite® multi UV sheets without such supports!

Tip: For your own safety use planks, rigid board or similar items, when installing and cleaning the roof and abide by the appropriate safety regulations. Be careful not to damage the sheets and the sheet surface during the process.

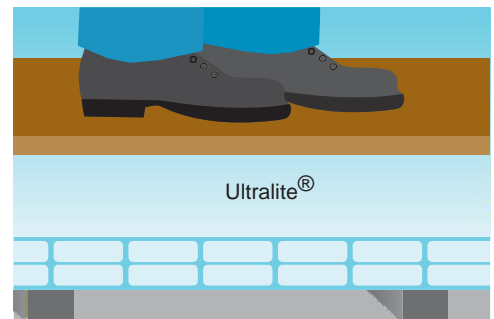
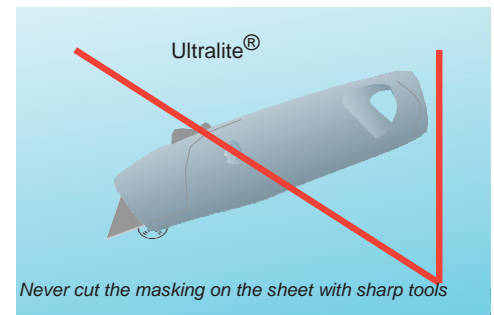
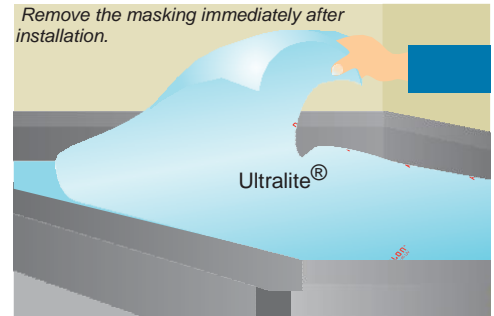

Never walk directly on the sheets



■ INSTALLATION

4. IMPORTANT REMARKS

The effect of condensation

In the atmosphere around us there is always some natural humidity - known as relative humidity (R.H.). This is the ratio, in percentage terms, between the quantity of water present in a certain volume of air and the maximum quantity that the same volume can contain as vapor without condensation.

When the temperature decreases, the air reduces its capacity to contain water vapour, so the value of the relative humidity depends not only on the quantity of water present but also on its temperature.

If the capacity of the air to contain water vapor is exceeded (also called the dew point), this vapor will condense into liquid drops. A typical example is the dew which occurs in meadows and gardens in some periods of the year, during the night, when the temperature drops.

Condensation can affect the Ultralite® multi UV sheets in two different ways:

1. Inside the hollow chambers.

Polycarbonate has a certain permeability to water vapor and inside the hollow chamber there will always be humid air with variable percentages of relative humidity (R.H.). Whenever the temperature inside the hollows decreases under the dew point, the humid air will condense into water drops.

This effect must be taken into consideration when choosing the right direction of the ribs and the right method of sealing the sheet edges.

Excessive condensation is in many cases due to the infiltration of rainwater or to clogging of the condensation drains in the end closure section. To prevent this, installation

should be performed correctly according to our guidelines and attention must be paid to careful mounting of the end-closure sections.

2. On the inner surface of the sheet.

Whenever the microclimatic conditions (local temperature of the sheet and relative humidity of the air around it) on the inner surface of the sheet reaches the dew point there will be condensation on the sheet surface.

The water drops on the inner surface can have several consequences: diminution of the light transmission, damage to cultivated plants below if the drops fall, formation of water pools on the floor, etc.

This will typically occur in greenhouses or on swimming pool covers. It can be considered and calculated in advance and avoided by choosing a sheet with 'no drop' coating.

With the diagram on the next page, one can find out what temperatures (inside and outside the building) and humidity (inside the building) will cause condensation to form, depending on the U_g value of the sheet. Sheets with a high insulation (low U_g -value) will have a higher temperature on the inner surface and can tolerate more relative humidity without the effect of condensation. However, the effect of condensation can't always be avoided especially in the coldest countries.



■ INSTALLATION

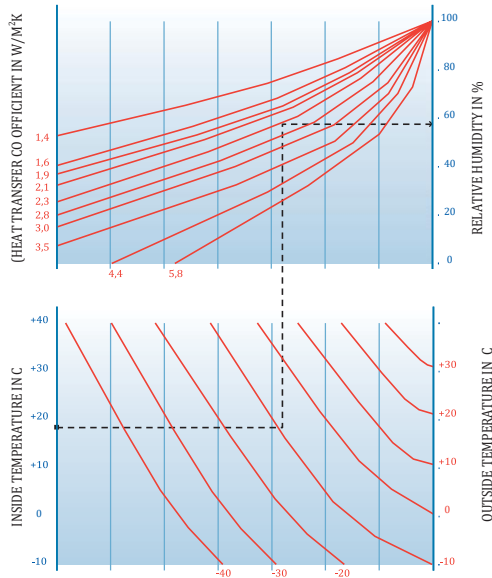

How to use the diagram:

1. Determine in the lower diagram where the curve representing the outside temperature crosses the horizontal line representing the inside temperature (in this example: an inside temperature of 18 °C and an outside temperature of -10 °C).
2. From this point, draw a vertical line to the diagram above.
3. Determine the Ug value of the glazing in the diagram above (example: 2.8 W/m²K for Ultralite® multi UV 3/16-16).
4. Where the vertical line you have just drawn crosses the line representing the Ug value, you will find on the right hand side the dew point (in the example: with a relative humidity of 55%, condensation will occur on the glazing).

Rib direction

Ultralite® is permeable to water vapor, which means that a tiny quantity of water can permeate through the sheet surface into the hollow chambers. This in turn may lead to condensation inside the sheet (see previous chapter).

We would therefore make the following recommendations:

- Never install Ultralite® multi UV sheets with the hollows in a flat position. The sheets must have a slope in the direction of the ribs to allow drainage of any condensation. A minimum slope of 5° (= 90 mm/m) is recommended.
- For the same reason, in case of a vertical installation, the sheets must be installed with the ribs in vertical position.

Not following these suggestions may cause the accumulation of condensation inside the sheet, leading to the growth of moss or moulds.

Of course this effect doesn't occur with installations in inner spaces where there are no temperature differences. In such cases Ultralite® multi UV sheets can be installed with the ribs in a horizontal position.





■ INSTALLATION

Cleaning

Ultralite® sheets can be cleaned using a soft clean sponge by washing with lukewarm water containing a mild soap or a slightly acidic or neutral detergent. Rinse well afterwards with clean water and dry with a chamois or a moist cellulose sponge.

Fresh paint splashes, grease, smeared glazing compounds, etc. can be removed before drying by rubbing lightly with ethyl alcohol or petroleum ether on a soft cloth followed by a thorough wash and rinse as described above.

Larger areas can also be cleaned with high pressure water and/or steam cleaner (max. 80° C). Move the water jet continuously to minimise prolonged contact on the same part of the surface.

Remark: Cleaners and solvents generally recommended for use on PC are not always compatible with the UV protected surface of Ultralite® sheets.

■ STATICS



If Ultralite® multi UV is used in roofing or walls, the forces from wind and snow must be absorbed by a suitable sub-structure. We recommend taking the support distance for each load from the diagrams in annex.

For flat and barrel vault applications the system resistance (bounding state of load bearing capacity) of our Ultralite® multi UV sheets has been determined/estimated in accordance with European guideline.

All calculations are based on extensive tests on real systems

The loads are applied as uniformly distributed linear loads; i.e. load components acting vertically on the sheet, both load and suction.

These values are guide values, which were assumed or in extensive tests on real systems. Adequate safety values, which should be assessed on a case-by-case basis, are to be observed with regard to these values. The values are assumed /calculated with an adequate safety factor. However, this does not replace the country-specific certifications prescribed by the building inspectorate.

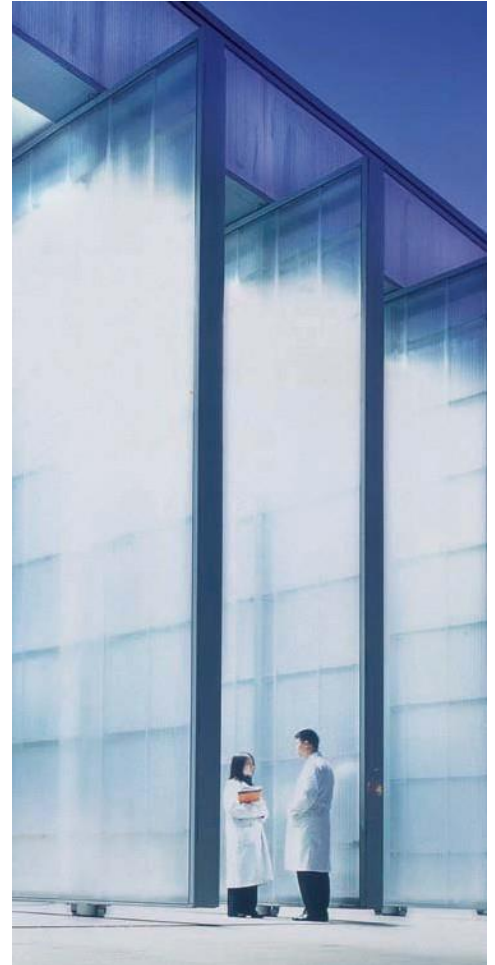

■ STATICS

FLAT APPLICATIONS

Load-bearing characteristics

The characteristic values of the system resistance have been determined in an unfavourable situation, i.e. the sheets were not fixed, but laid loosely (free rotation) in real test. The curves show the load bearing capacity for Ultralite® multi UV sheets (supported on all sides with a rabbet depth of 20 mm) as a function of load via unsupported span with sheet width as the parameter.

In general, experience has shown that a safety factor of 1.3 is adequate with regard to the measured resistance values. This safety factor is included in the diagrams.

If the rabbet depth is smaller, the support distances should be reduced suitably for the given load.

If sufficiently stable profiles are used, the allowable load increases by a factor of 1.2. For pure wind loads (short time load) the allowable load increases again by a factor of 1.1.

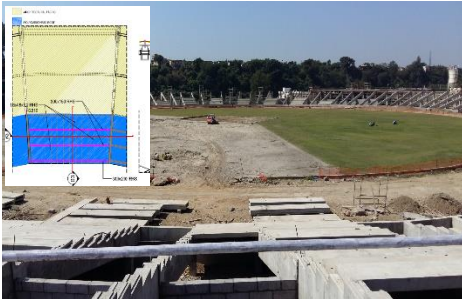

How to use the diagrams:

1. Select your sheet type.
2. At a given load you will find the unsupported span, depending on the sheet width, on the abscissa.
3. If unsupported span is too low, switch over to sheets with higher load-bearing capacities or use reduced sheet width.

Example: (see diagram on next page)

Type of sheet: Ultralite® multi UV 2/6-6 (twin wall 6 mm)

Expected wind load: $800 \text{ N/m}^2 (= 0,8 \text{ kN/m}^2)$

If the sheet is installed with 700 mm width, it can have an unsupported span (length) of 2150 mm.

If the sheet is installed with 1050 mm width, it can have an unsupported span (length) of 1650 mm.

For load bearing calculation of curved glazing applications, please contact our Technical Service.



STATICS

LOAD BEARING CHARACTERISTICS OF -ULTRALITE MULTI UV 2/6-6 FLAT GLAZED

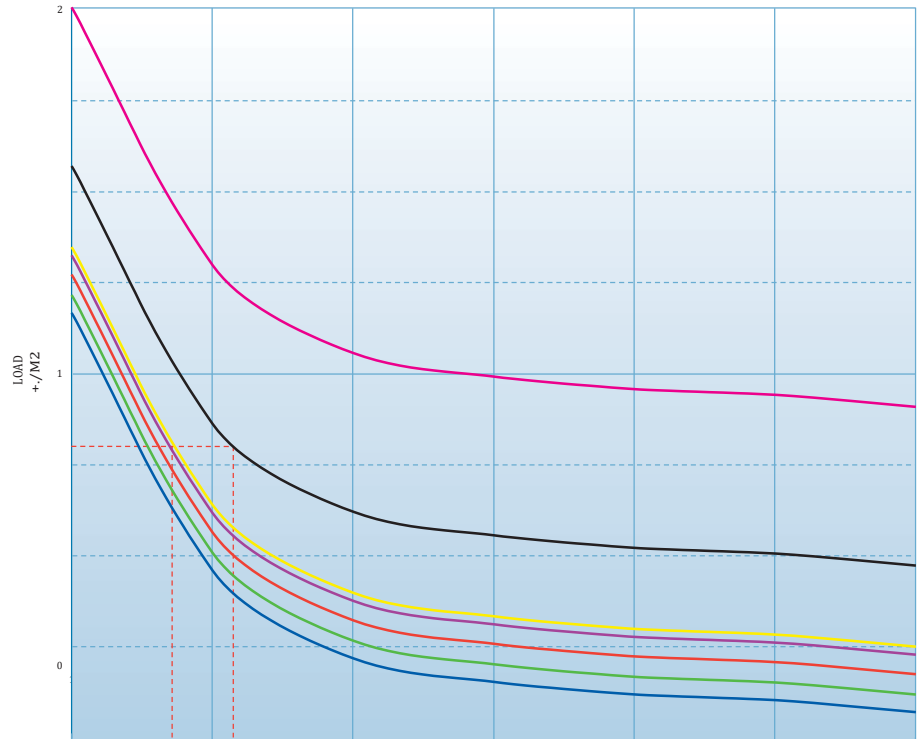

- width = 500 mm
- width = 700 mm
- width = 980 mm
- width = 1050 mm
- width = 1200 mm
- width = 1500 mm
- width = 2100 mm

LOAD BEARING CHARACTERISTICS OF -ULTRALITE MULTI UV 2/8 -10.5 FLAT GLAZED

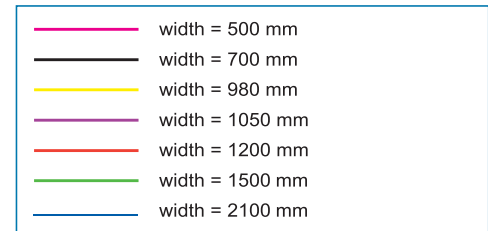
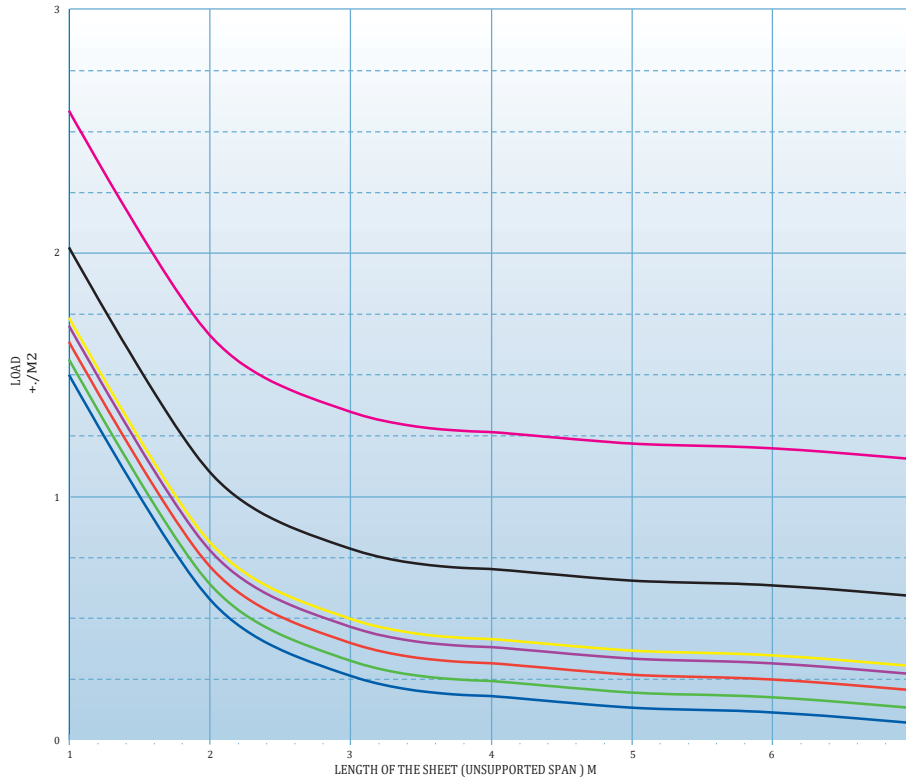

STATICS

LOAD BEARING CHARACTERISTICS OF -ULTRALITE MULTI UV 4/8-6 FLAT GLAZED

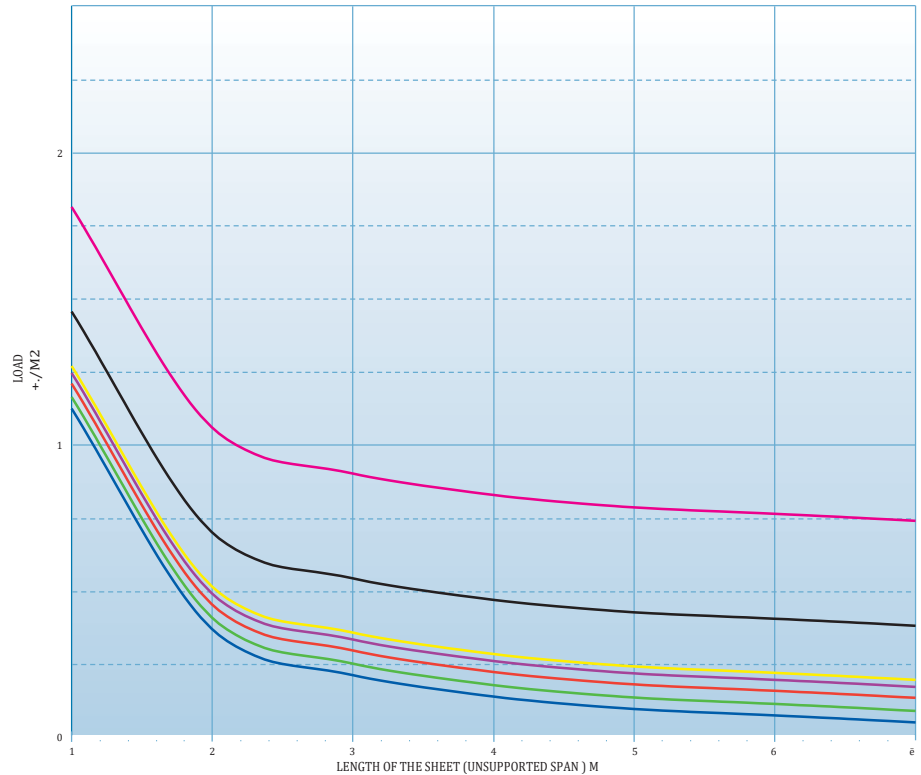

- width = 500 mm
- width = 700 mm
- width = 980 mm
- width = 1050 mm
- width = 1200 mm
- width = 1500 mm
- width = 2100 mm

LOAD BEARING CHARACTERISTICS OF -ULTRALITE MULTI UV 2/10-10.5 FLAT GLAZED

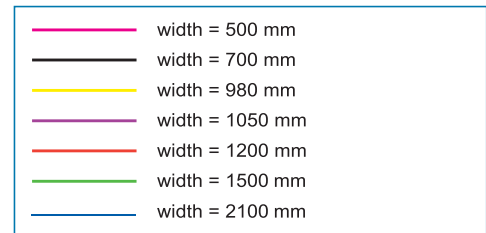
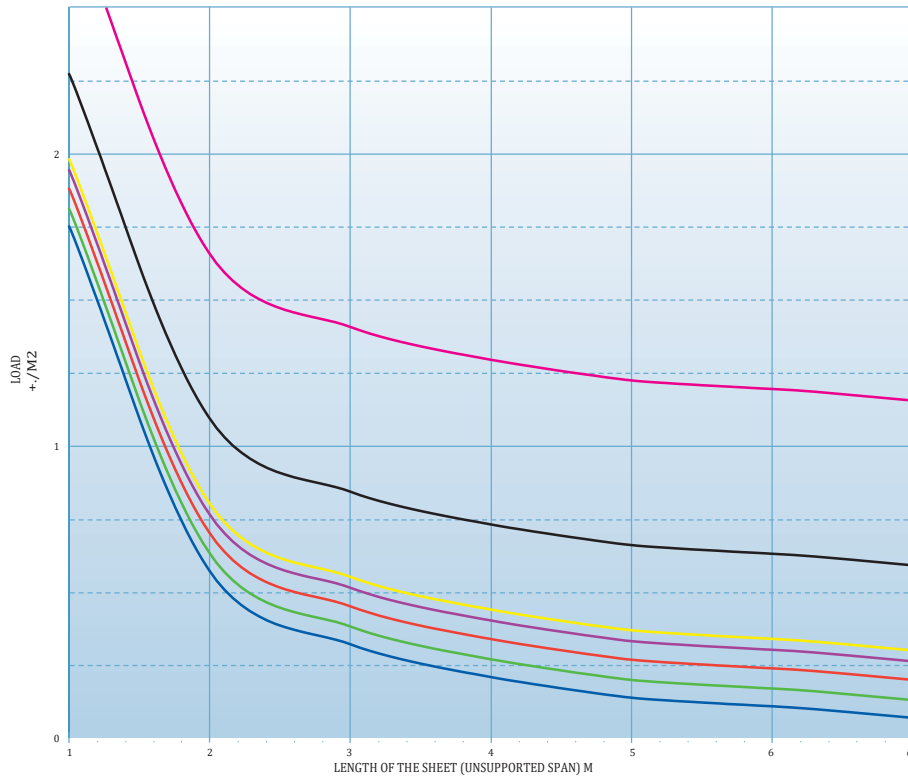

STATICS

LOAD BEARING CHARACTERISTICS OF ULTRAITE MULTI UV 4/10-6 FLAT GLAZED

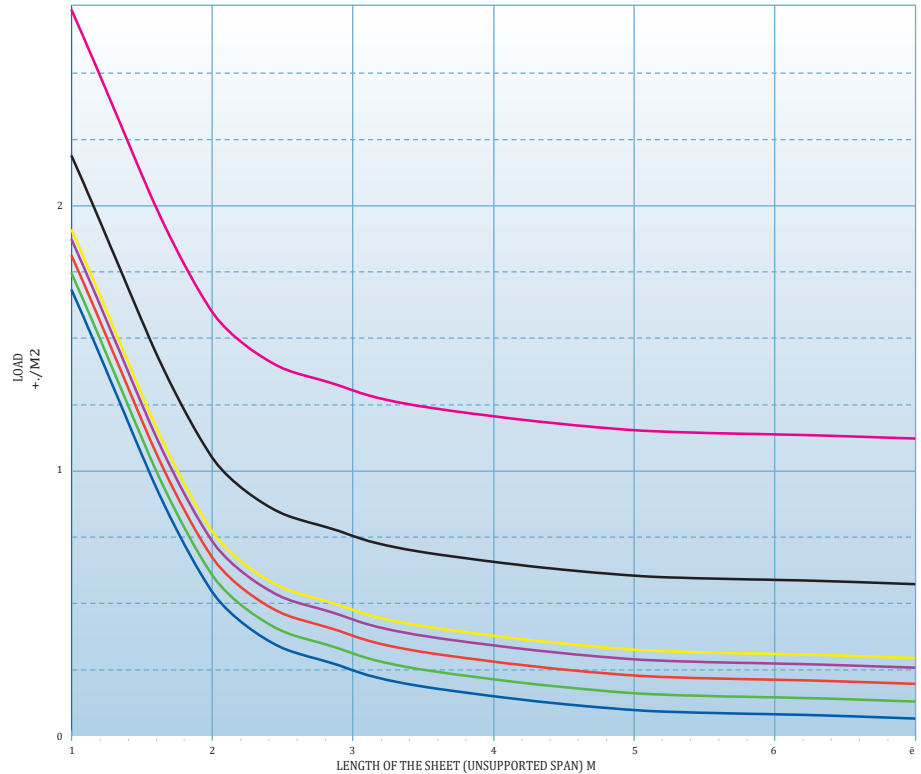

- width = 500 mm
- width = 700 mm
- width = 980 mm
- width = 1050 mm
- width = 1200 mm
- width = 1500 mm
- width = 2100 mm

LOAD BEARING CHARACTERISTICS OF ULTRALITE MULTI UV 3/16-16 FLAT GLAZED

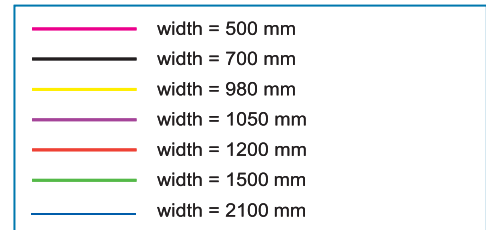
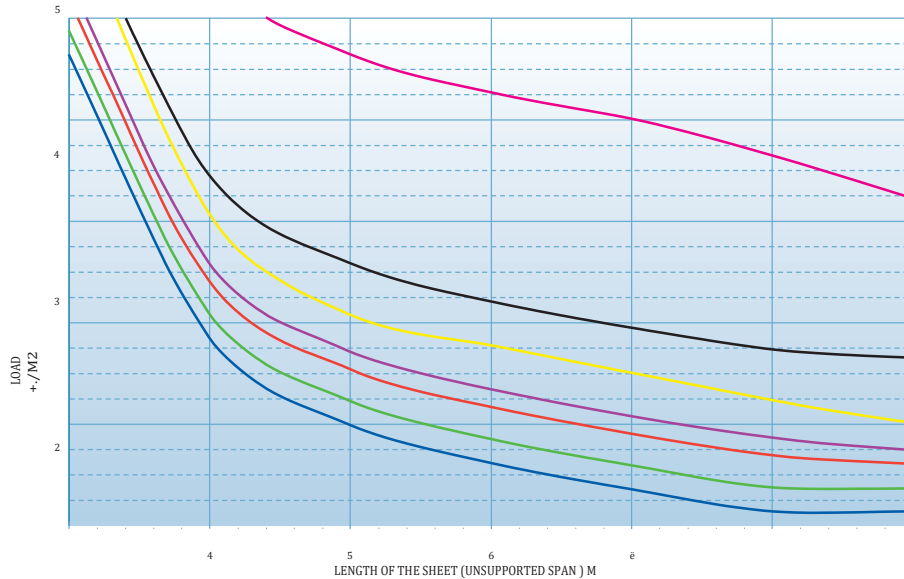

LOAD BEARING CHARACTERISTICS OF -AKROLON MULTI UV 5M/25-25 FLAT GLAZED

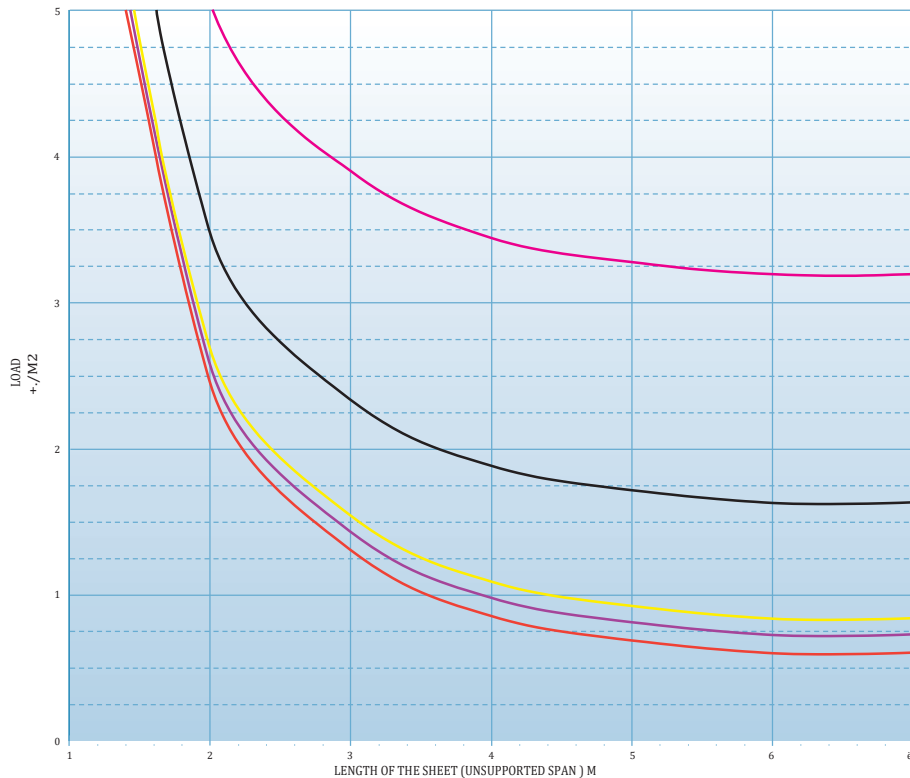

This diagram is also valid for:
 Future Products
 Ultralite® multi UV 5X/32-25
 Ultralite® multi UV 5X/40-25

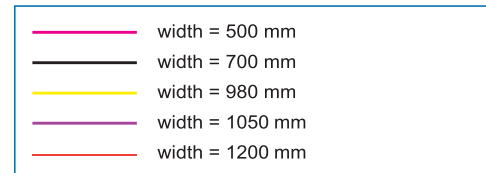

Ultralite®

Saraswati Plastotech India Pvt Ltd

Lane 4, Phase 1, Sidco

Industrial Complex, Bari Brahmna, Jammu 181133

Email: plasto.saraswati@gmail.com

www.saraswati-group.com

Ultralite® is registered trademarks of Saraswati Plastotech India Pvt Ltd.

Product Liability Clause: This information and our technical advice - whether verbal, in writing or by way of trials - are given in good faith but without warranty, and this also applies where proprietary rights of third parties are involved. Our advice does not release you from the obligation to verify the information currently provided - especially that contained in our safety data and technical information sheets - and to test products as to their suitability for the intended processes and uses. The application, use and processing of our products and the products manufactured by you on the basis of our technical advice are beyond our control and, therefore, entirely your own responsibility. Our products are sold in accordance with the current version of our General Conditions of Sale and Delivery.